



SPP

*Southwest
Power Pool*

***Impact Study
For
Generation Interconnection
Request
GEN-2006-037***

SPP Tariff Studies

(#GEN-2006-037)

April, 2007

Summary

Pursuant to the tariff and at the request of the Southwest Power Pool (SPP), Black & Veatch performed the following Impact Study to satisfy the Impact Study Agreement executed by the requesting Customer and SPP for SPP Generation Interconnection request #GEN-2006-037.

Interconnection Facilities

No new facilities were determined to be necessary by this Impact Study. The estimated Interconnection Facility and Network Upgrade Costs were given in the Feasibility Study. These costs are re-stated below in Table 1 and Table 2. These costs do not include the results of short circuit analysis. Detailed facility costs and a short circuit analysis will be conducted by the Transmission Owner during a Facility Study, if the Customer wishes to execute a Facility Study Agreement for this generation interconnection request.

Table 1: Direct Assignment Facilities

| Facility | ESTIMATED COST (2006 DOLLARS) |
|--|----------------------------------|
| Customer – 345kV-GSU voltage Substation facilities. | * |
| Customer – 345kV facilities between Customer facilities and OKGE Sooners Energy Center 345kV switching station | * |
| Customer - Right-of-Way for Customer facilities. | * |
| Total | * |

Note: *Estimates of cost to be determined by Customer.

Table 2: Required Interconnection Network Upgrade Facilities

| Facility | ESTIMATED COST (2006 DOLLARS) |
|--|----------------------------------|
| OKGE – Add a 345kV generator/line terminal to the existing Sooner 345kV Substation bus including two 345kV circuit breakers, associated switches, buswork, relaying and all miscellaneous equipment. | \$2,000,000 |
| Total | \$2,000,000 |

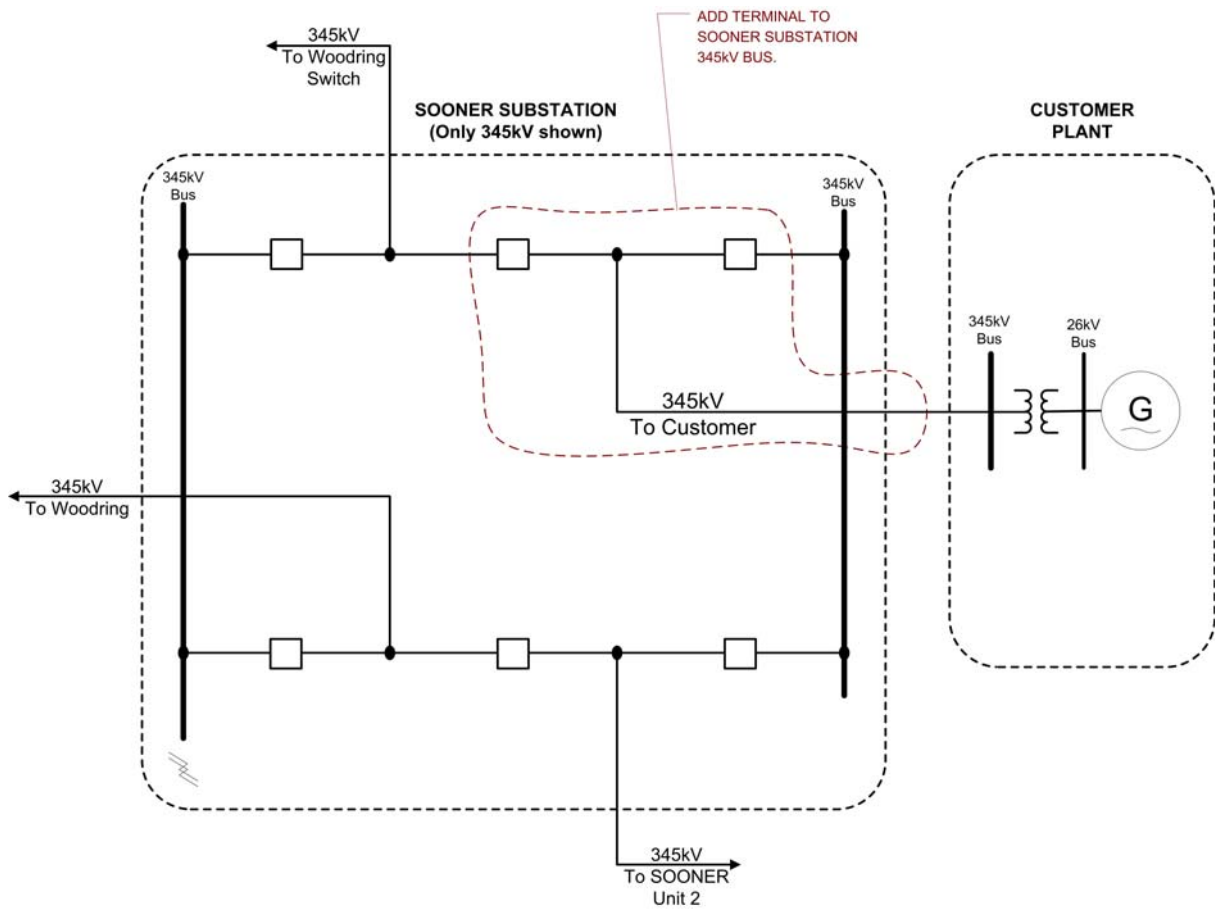

Figure 1: Proposed Interconnection
(Final substation design to be determined)

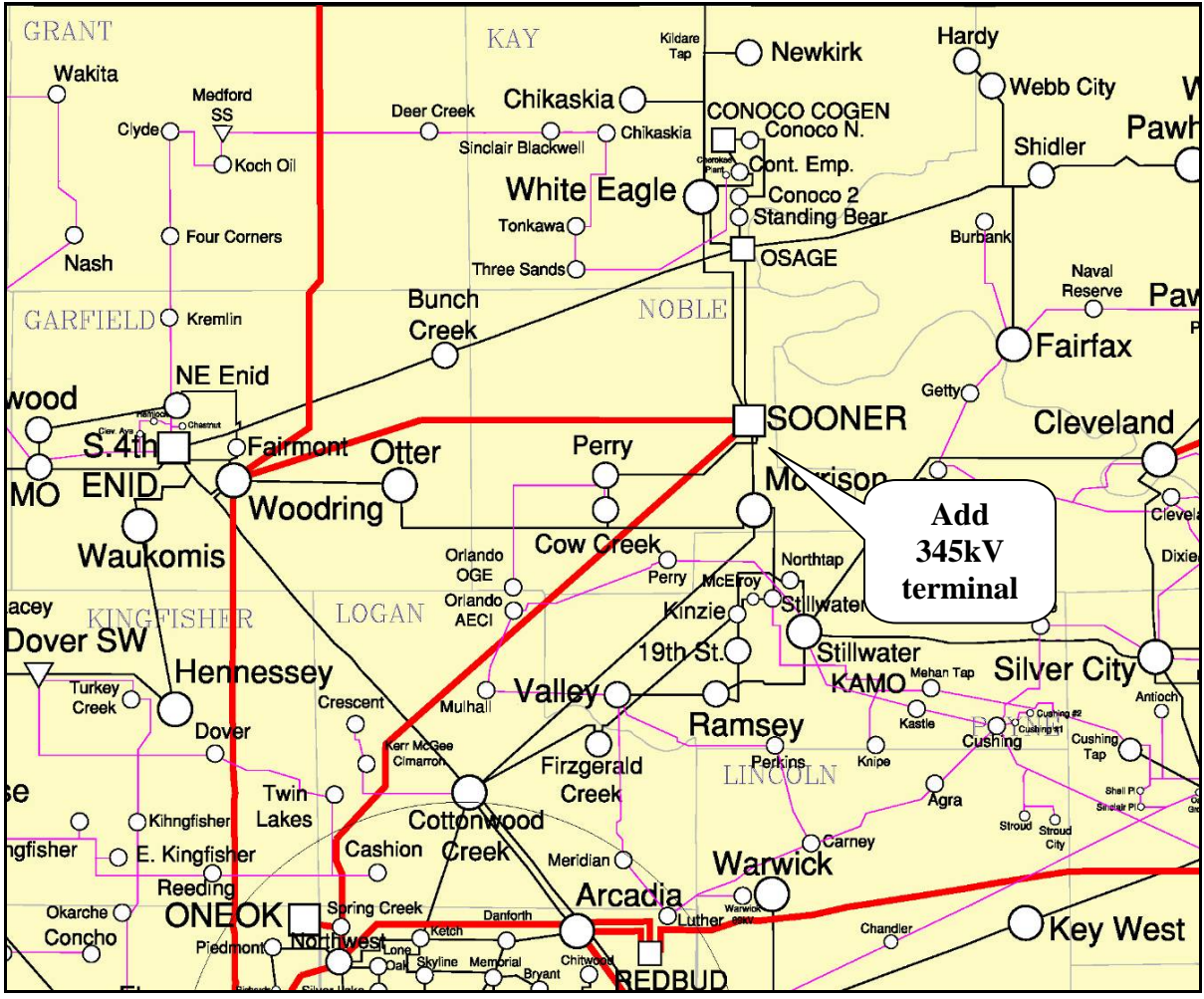

Figure 2. MAP OF THE LOCAL AREA

**IMPACT STUDY FOR SPP GENERATION
QUEUE POSITION GEN-2006-037**

SOUTHWEST POWER POOL (SPP)

April 25, 2007

Final Report

By



BLACK & VEATCH

Table of Contents

| | |
|------------------------------------|----|
| <i>EXECUTIVE SUMMARY</i> | 3 |
| <i>1. INTRODUCTION</i> | 4 |
| <i>2. STABILITY STUDY CRITERIA</i> | 4 |
| <i>3. SIMULATION CASES</i> | 5 |
| <i>4. SIMULATION MODEL</i> | 7 |
| <i>5. STUDY ASSUMPTIONS</i> | 8 |
| <i>6. SIMULATION RESULTS</i> | 8 |
| <i>7. SUMMARY</i> | 10 |

EXECUTIVE SUMMARY

A transient stability study has been performed for Southwest Power Pool (SPP) Interconnection Queue Position GEN-2006-037 as part of the System Impact Study. The Interconnection Queue Position GEN-2006-037 is a coal-fired steam turbine generator with a capacity of 893 MW (Summer) /925 MW (Winter) located in Noble County, Oklahoma. The generation facility will be interconnected to the Sooner 345kV substation on the Oklahoma Gas & Electric (OKGE) transmission system.

The SPP MDWG 2006 series models of the 2011 summer peak and 2007 winter peak load flow case together with the SPP MDWG 2006 stability model were used as the base case for the transient stability analysis. The study was performed using PTI's PSS/E program, which is an industry-wide accepted power system simulation program.

Transient Stability studies were conducted with the 100% total capacity of 893 MW in the summer and 925 MW in the winter. Twenty two (22) contingencies were considered for each of the scenarios.

The study has not indicated any angular or voltage instability problem for the contingencies analyzed after the addition of GEN-2006-037.

If any previously queued projects that were included in this study drop out then this System Impact Study may have to be revised to determine the impacts of this Interconnection Customer's project on OGKE transmission facilities.

1. INTRODUCTION

This report discusses the results of a transient stability study performed for Southwest Power Pool (SPP) Interconnection Queue Position GEN-2006-037.

The Interconnection Queue Position GEN-2006-037 is a generating facility with a coal fired steam turbine generator of total capacity of 893 MW (Summer) / 925 MW (Winter). The generating facility will be located in Noble County, Oklahoma within the service territory of Oklahoma Gas and Electric Company and will be interconnected to Sooner 345kV substation. The system one line diagram of the area near the Queue Position Gen-2006-037 is shown below.

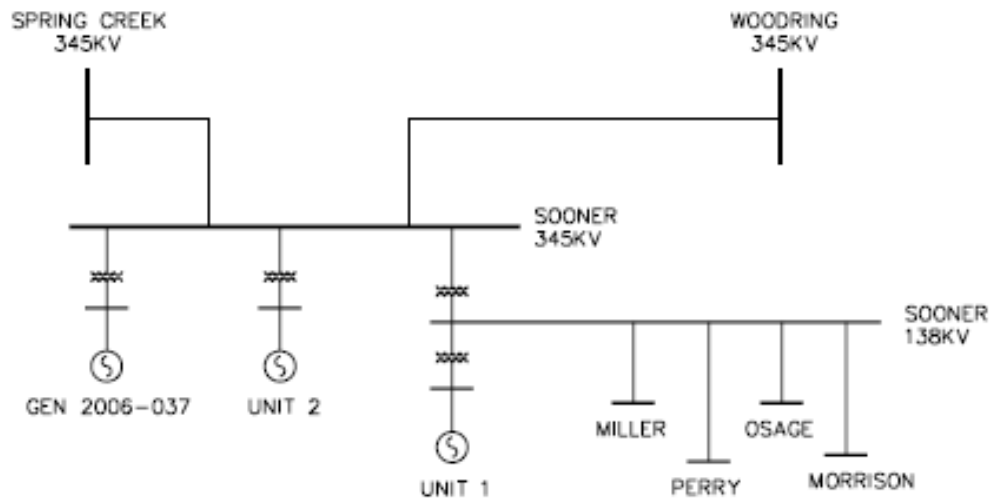

Figure 1: System One Line Diagram near GEN-2006-037

Transient Stability studies were conducted with the 100% total capacity, i.e., 893 MW in summer case and 925 MW in winter case. The data for the new turbine generator were provided by the Customer for the study.

2. STABILITY STUDY CRITERIA

The SPP MDWG 2006 series 2011 summer peak and 2007 winter peak load flow cases together with the SPP MDWG 2006 stability model database were used as the base case for the transient stability analysis. These models were provided by SPP.

Using Planning Standards approved by NERC, the following stability definition was applied in the Transient Stability Analysis:

“Power system stability is defined as that condition in which the difference of the angular positions of synchronous machine rotor becomes constant following an aperiodic system disturbance.”

Disturbances such as three phase and single phase line faults were simulated for a specified duration and the synchronous machine rotor angles were monitored for their synchronism following the fault removal.

The ability of the wind generators to stay connected to the grid during the disturbances and during the fault recovery was also monitored.

3. SIMULATION CASES

Transient Stability studies were conducted with the Gen-2006-037 output at 100% for two scenarios, i.e., (i) 2011 summer peak load and (ii) 2007 winter peak load.

Table 1 indicates the contingencies which were studied.

| Fault Number | Fault Definition |
|---------------------|--|
| FLT13PH | Three phase fault on the Sooner –Woodring 345 kV line, near Sooner, with one shot reclosing after 20 cycles. |
| FLT21PH | Single phase fault on the Sooner –Woodring 345 kV line, near Sooner, with one shot reclosing after 20 cycles. |
| FLT33PH | Three phase fault on the Sooner –Spring Creek 345 kV line, near Sooner with one shot reclosing after 20 cycles. |
| FLT41PH | Single phase fault on the Sooner –Spring Creek 345 kV line, near Sooner with one shot reclosing after 20 cycles. |
| FLT53PH | Three phase fault on the Sooner autotransformer – 345 kV bus. |
| FLT61PH | Single phase fault on the Sooner autotransformer – 345 kV bus. |
| FLT73PH | Three phase fault on the Sooner - Miller 138 kV line, near Sooner with one shot reclosing after 20 cycles. |
| FLT81PH | Single phase fault on the Sooner - Miller 138 kV line, near Sooner with one shot reclosing after 20 cycles. |
| FLT93PH | Three phase fault on the Sooner- Morrison 138 kV line, near Sooner with one shot reclosing after 20 cycles. |

| | |
|----------|---|
| FLT101PH | Single phase fault on the Sooner- Morrison 138 kV line, near Sooner with one shot reclosing after 20 cycles. |
| FLT113PH | Three phase fault on the Sooner - Perry 138 kV line, near Sooner with one shot reclosing after 20 cycles. |
| FLT121PH | Single phase fault on the Sooner - Perry 138 kV line, near Sooner with one shot reclosing after 20 cycles. |
| FLT133PH | Three phase fault on the Sooner - SNRPMPT 138 kV line, near Sooner with one shot reclosing after 20 cycles. |
| FLT141PH | Single phase fault on the Sooner - SNRPMPT 138 kV line, near Sooner with one shot reclosing after 20 cycles. |
| FLT153PH | Three phase fault on the Woodring - Wichita 345 kV line, near Woodring with one shot reclosing after 20 cycles. |
| FLT161PH | Single phase fault on the Woodring - Wichita 345 kV line, near Woodring with one shot reclosing after 20 cycles. |
| FLT173PH | Three phase fault on the Woodring - Cimarron 345 kV line, near Woodring with one shot reclosing after 20 cycles. |
| FLT181PH | Single phase fault on the Woodring - Cimarron 345 kV line, near Woodring with one shot reclosing after 20 cycles. |
| FLT193PH | Three phase fault on the Redbud - Riverside 345 kV line, near Redbud with one shot reclosing after 20 cycles. |
| FLT201PH | Single phase fault on the Redbud - Riverside 345 kV line, near Redbud with one shot reclosing after 20 cycles. |
| FLT213PH | Three phase fault on the Northwest - Arcadia 345 kV line, near Arcadia with one shot reclosing after 20 cycles. |
| FLT221PH | Single phase fault on the Northwest - Arcadia 345 kV line, near Arcadia with one shot reclosing after 20 cycles. |

Table 1: Study Cases

4. SIMULATION MODEL

Gen-2006-037 is a coal-fired steam turbine generator. The following are the main parameters of the turbine generator unit and Table 2 shows the electrical parameters of the generators.

| | |
|--------------------|------------|
| Rated Power | : 925 MW |
| Voltage | : 26,000 V |
| Rated Power Factor | : 0.90 |

The Customer also provided the following Generator Step-up Transformers impedance:

Transformer Impedance: 10 % on 990 MVA

The generating unit was considered to be connected with the Sooner substation directly via GSU.

The models of the generating station equipment such as generators and transformers were added to the base case for the purpose of this study.

Prior queued project GEN-2005-024 was included in the study model, with its energy being displaced in the AEPW control area. Spring Creek was brought on line in the winter model and its energy was dispatched into the Westar control area. Spring Creek was already on line in the summer model. Also, Redbud was brought on line at 487MW in the winter and summer model with its energy being displaced in the Entergy control area.

No additional transmission lines were added to either the MDWG 2006 series winter or summer stability loadflow model.

| Description | Value |
|--|-------|
| Open Circuit Transient Time Constant, T'D0 | 5.90 |
| Open Circuit Subtransient Time Constant, T''D0 | 0.034 |
| Open Circuit Quadrature axis Time Constant, T'Q0 | 0.69 |
| Open Circuit Quadrature axis Subtransient Time Constant, T''Q0 | 0.067 |
| Inertia Constant, H | 3.13 |
| Synchronous reactance, XD | 2.18 |
| Quadrature axis reactance, XQ | 2.07 |
| Transient Reactance, X'D | 0.28 |

| | |
|--|-------|
| Quadrature axis Transient Reactance, X'Q | 0.465 |
| Sub transient Reactance, X''D | 0.23 |
| Leakage reactance, XL | 0.155 |

Table 2: Generator Parameters

5. STUDY ASSUMPTIONS

The following assumptions were made in the Study:

1. The generation in the SPP control area were scaled down to accommodate the new generation as indicated in Table 3.

| Scenario | Generation within SPP | |
|--------------------------|-----------------------|-----------|
| | Summer | Winter |
| With the GEN-2006-037 | 38,742 MW | 26,894 MW |
| Without the GEN-2006-037 | 37,849 MW | 25,969 MW |

Table 3: SPP Dispatches

6. SIMULATION RESULTS

Initial simulation was carried out for 20 seconds without any disturbance to verify the numerical stability of the model and was confirmed to be stable.

Table 4 provides the summary of the stability studies for Gen-2006-037.

| Fault Number | Summer Peak | Winter Peak |
|--------------|-------------|-------------|
| FLT1_3PH | -- | -- |
| FLT2_1PH | -- | -- |
| FLT3_3PH | -- | -- |
| FLT4_1PH | -- | -- |
| FLT5_3PH | -- | -- |
| FLT6_1PH | -- | -- |
| FLT7_3PH | -- | -- |
| FLT8_1PH | -- | -- |

| | | |
|-----------|----|----|
| FLT9_3PH | -- | -- |
| FLT10_1PH | -- | -- |
| FLT11_3PH | -- | -- |
| FLT12_1PH | -- | -- |
| FLT13_3PH | -- | -- |
| FLT14_1PH | -- | -- |
| FLT15_3PH | -- | -- |
| FLT16_1PH | -- | -- |
| FLT17_3PH | -- | -- |
| FLT18_1PH | -- | -- |
| FLT19_3PH | -- | -- |
| FLT20_1PH | -- | -- |
| FLT21_3PH | -- | -- |
| FLT22_1PH | -- | -- |

UV : Tripped due to low voltage
 OV : Tripped due to high voltage
 UF : Tripped due to low frequency
 OF : Tripped due to high frequency
 S : Stability issues encountered

Table 4 : Stability Study Results Summary

GEN-2006-037 and the rest of the system were found to be stable for all the contingencies that were studied.

Figure 2 shows the system response for FLT1_3PH in summer peak load case.

7. SUMMARY

A transient stability analysis was conducted for the SPP Interconnection Generation Queue Position GEN-2006-037 with the maximum output of 893 MW in summer and 925 MW in winter. The study was conducted for two different power flow scenarios, i.e., one for 2011 summer peak load and the other for 2007 winter peak load. The study has not indicated any instability in the system with the addition of GEN-2006-037.

Disclaimer

If any previously queued projects that were included in this study drop out, then this System Impact Study may have to be revised to determine the impacts of this Interconnection Customer's project on OKGE transmission facilities. Since this is also a preliminary System Impact Study, not all previously queued projects were assumed to be in service in this System Impact Study. If any of those projects are constructed, then this System Impact Study may have to be revised to determine the impacts of this Interconnection Customer's project on OKGE transmission facilities. In accordance with FERC and SPP procedures, the study cost for restudy shall be borne by the Interconnection Customer.

Figure 2 : System Responses with 100% output of Gen-2006-037

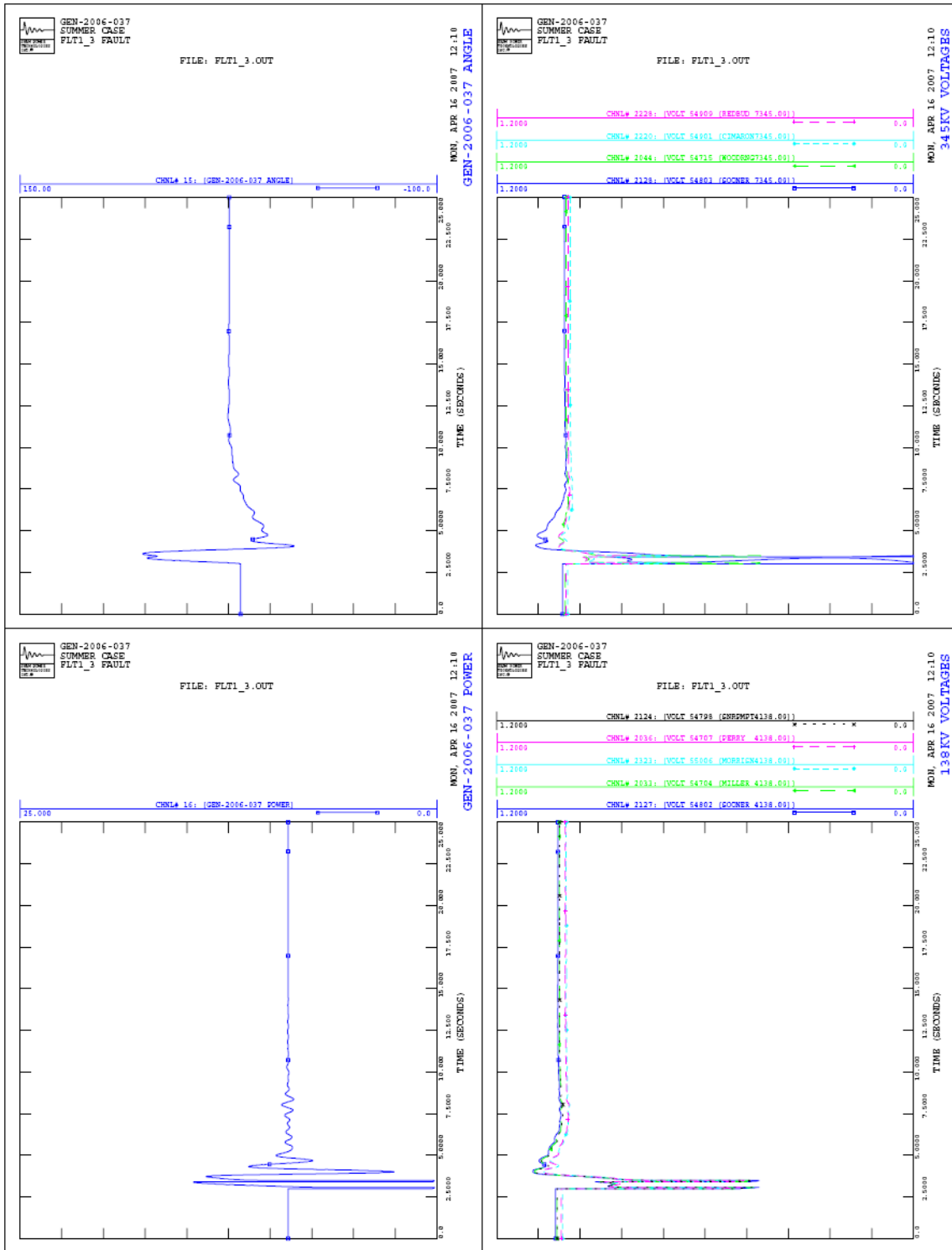

Figure 2 : System Responses with 100% output of Gen-2006-037 (Cont'd)

